



Amplifying income potential of three wheeler auto-rickshaw drivers: Case for dual licensing policy

Report prepared by:

Centre for Digital Economy Policy Research

&

Prof. Anoop Chawla, Indian Institute of
Technology, Delhi

Amplifying income potential of three wheeler auto-rickshaw drivers: Case for dual licensing policy

Report prepared by

Centre for Digital Economy Policy

&

Prof Anoop Chawla, Indian Institute of Technology Delhi

A handwritten signature in grey ink, appearing to read 'Anoop Chawla', is positioned to the left of the text 'Centre for Digital Economy Policy'.

Amplifying income potential of auto-rickshaws and economic growth: Inputs for dual usage license policy

Summary

The present paper seeks to study the scope of amplifying the income potential of the three wheeler auto-rickshaw drivers through adoption of dual licensing permits for three wheeler auto-rickshaws. The three wheeler drivers have no alternative means to engage in any other economic activity to enhance the earnings during the idle time resulting in a perpetual state of economic hardships. The three wheeler auto rickshaws that they own/drive is the only income generating asset with them. Having been restricted to passenger carrying, they have no other way but operate at a low-level of economic activity and income. This paper argues that through a light-touch regulation it is possible to optimize the utilisation of their assets by carrying goods in their idle time and thereby improve their economic well-being. With this objective in mind, the study also seeks to address the safety aspects of three wheeler autos at par with the safety features currently in place for carrying passengers.

Auto-rickshaws in India

Auto-rickshaws, a small three wheeled motorized vehicles are omnipresent in urban and semi urban India and are important elements of the cultural landscape¹. They play an important role in urban transport in the country and being used for a wide range of trips, often fulfilling the last mile connectivity issues at a cost reasonably lower than taxis².

According to an estimate, there were 8 million auto-rickshaws in India³. Auto-rickshaws are preferred by a larger middle-class and lower class population groups as the cost of taxi rides is prohibitive. The auto drivers are in the age group of 30-39 years and normally work for 25 days monthly. The daily working hours are approximately 10-12 hours a day⁴. The mean distance travelled per day varies from 70 to 80 kms. At an average speed of 25kmph, it amounts to a utilization of about 30-35% only. On an average, the monthly earnings range from INR 4000 to INR 15000⁵ after offsetting all expenses including fuel and maintenance. Most of the auto-rickshaws are not owned by the drivers themselves. If the auto-rickshaws are rented, the income comes down further. The squeeze on the auto-rickshaws' income seems to have increased with the introduction of app-based taxis like Uber and Ola.

The current licensing regime prohibits passenger carrying three-wheeler autos to carry goods. However, passenger autos end up carrying goods in order to increase the revenues at the risk of law violation. This is a result of the idle time of the autos which is almost six out of twelve work hours⁶ of the drivers.

¹ Chhabra D., Chowdhury, A., & Chowdhury, J. (2021) Examining sustainability of heritage on wheels: the case of autorickshaws in Delhi (India), *Journal of Heritage Tourism*, 16:3, 349-362, DOI: 10.1080/1743873X.2020.1788567

² Harding, S. E., Badami, M. G., Reynolds, C. C., & Kandlikar, M. (2016). Auto-rickshaws in Indian cities: Public perceptions and operational realities. *Transport Policy*, 52, 143-152.

³ <https://www.climateworks.org/blog/rickshaws-riding-toward-a-green-and-just-recovery-in-india-today/>

⁴ Gadapalli, R. (2016). Role of intermediate public transport in Indian cities. *Economic and Political Weekly*, 46-49.

⁵ Debbarma, D., Mitra, S., & Debnath, P. (2017). A Comparative Assessment on the Working and Living Conditions of the Auto Rickshaw Service Providers of Dharmanagar and Udaipur Town of Tripura. *Global Journal of Advanced Research*, 4 (9), 281-289.

⁶ <https://theprint.in/the-fineprint/how-cng-prices-have-taken-the-gas-out-of-delhis-auto-drivers-and-their-livelihoods/952639/>

Despite the challenges, driving auto-rickshaws offers significant livelihood opportunities for low educated youth in India. The growth of auto-rickshaws in modern India can be substantiated with data points from Bangalore, Mumbai, Pune and Rajkot which show that auto-rickshaws serve between 10 to 20⁷ percent of daily motorized urban transport trips. Additionally, it is estimated that the total daily passenger trips in 87 major urban centers in India will more than double from around 229 million in 2007 to around 482 million in 2031⁸. With the increasing population and faster urbanization rate, number of auto-rickshaw units are likely to significantly increase in India. Early research indicates that perception about auto-rickshaws being unsafe could be re-examined as the number of deaths due to auto-rickshaws is lower than other factors. In 2020, percentage of all people killed under auto-rickshaw category is only 3.9% when compared to 43.5% two-wheelers and 13.7% cars, taxis, vans & light motor vehicles categories⁹.

What if passenger auto-rickshaws are permitted to carry the goods? What are the benefits?

Benefits of dual usage license

Enhanced income

When there is optimum utilization of assets, the income of the drivers capita will significantly increase adding to enhanced per capita of the city. It could be gathered that¹⁰, an auto driver in Delhi collects INR 700 to INR 800 per day. He spends INR 200 to INR 300 to buy gas and food daily. Plus, they spend money on servicing monthly (INR 1000) and renewing permits (INR 2500). Therefore, their earning per day is INR 500-600. Additional trips due to dual usage may enable them to clock an additional, conservatively estimated, daily mileage of 60 kms resulting in an additional estimated gross income of INR 600; and after accounting fuel and food expenses they may have a net surplus of INR 300 – INR 400 per auto-rickshaw.

Ease of logistics management

We believe that the Indian logistics industry stands to gain from the dual license. The logistics industry has been growing at a CAGR 7-8% and is estimated to be \$380B by 2025 of which the intra city logistics accounts for \$46B.¹¹ However, in-city logistics is highly fragmented. On the demand side, small and medium enterprises (SMEs) contribute to the fragmentation due to their ad-hoc demand, low volume and diverse requirements. On the supply side, cargo auto-rickshaws are inadequate and cannot be summoned from other parts of the city due to information asymmetry. The passenger auto-rickshaws can contribute to the supply side, if the dual license is permitted. The idle time of the passenger auto-rickshaws can be utilized for ferrying goods which will help the logistics industry. The logistics management will be simplified wherein the small sized goods can easily be transported by auto-rickshaws leading to efficient logistics systems and higher economy growth.

⁷ <https://www.wri.org/outcomes/indian-city-launches-pioneering-auto-rickshaw-service>

⁸ <https://economictimes.indiatimes.com/industry/transportation/shipping/-transport/auto-rickshaw-crucial-for-sustainable-transport-study/articleshow/12028039.cms?from=mdr>

⁹ <https://morth.nic.in/road-accident-in-india> Please see Table 1 as Annex A for details.

¹⁰ Based on personal interactions with few auto drivers in New Delhi.

¹¹ <https://www.financialexpress.com/express-mobility/indian-logistics-sector-is-expected-to-reach-380-billion-mark-by-2025-nilesh-ghule-truckbhejo/2466424/>

Increased tax collection

There is a possibility of introduction of new licenses permitting dual usage. In other words, drivers can be asked to pay additional fees to acquire the dual license. Also, due to increased frequencies of cargo movements and consequent trade and commerce, there is a possibility of increased state tax revenue. There shall be a cascading effect – dual usage reduces cost of logistics which in turn shall increase the volume of logistics; this shall increase the volume of local internal trade resulting in higher tax collection.

Lowering of cost of doing business in the economy

It is expected that with dual use of auto-rickshaws, because of scale of economics, the marginal cost per unit of asset utilization will come down; logistic ease will also make it more cost effective. Since faster movement of cargo is possible because of dual usage point to point in-city movement of cargo, it will lower the operational cost for SMEs. The reduced cost might be shared between the SMEs and the customers.

Enhanced asset utilization/ optimization of assets in the economy

Dual licensing will enable auto-rickshaws to carry people and cargo. This will enhance the utilization of the auto-rickshaw as assets. The utilization value per vehicle would be higher because each asset (auto-rickshaw) would be put to a larger extent. If the average increase in daily distance travelled is 50-60 kms for each auto-rickshaw, dual usage is likely to increase the utilization from an estimated 30-35% to 60%.

In the light of above, the present paper discusses the possibilities of introducing dual license auto-rickshaws, wherein passenger autos are permitted to ferry goods.

Dual usage license & Safety

An argument that is often given against goods carriage in auto-rickshaws is the likely reduction in safety of the auto-rickshaw. In other words, it alleged that goods carriage would make the auto-rickshaws more unsafe. In this section we discuss the implications of this usage on safety, and how this can be addressed.

Needless to say, safety is of paramount concern. While a detailed safety analysis is beyond the scope at the moment, we hope to ensure that the safety of a cargo use / dual use auto-rickshaw is at least as good as that of a passenger use auto-rickshaw. Safety / stability of the auto-rickshaw would be effected by the weight it carries, the centre of gravity (CG) of the cargo/passengers, as well as other factors like ensuring containment of the cargo. We discuss these factors here.

Weight norms

A three-wheeler autorickshaw can carry four people – three passengers and one driver. The average Indian man and woman weighs 65 kg and 55 kg respectively,¹². The actual weight carried by them may actually be over 225kg in addition to the driver, keeping in mind variations in body weight and taking into account their personal belongings.

¹² <https://www.thehindu.com/news/cities/Hyderabad/ideal-body-weight-of-indian-men-now-65-kg-women-55-kg/article32736299.ece>

The same weight can be allowed for carrying goods. A tentative list of items and their weightage can be prepared. For instance, in case of cement bags, each one weighs 50kg. An auto-rickshaw should be allowed to carry a maximum of 4 cement bags.

Volumetric norms

Undoubtedly, the volume of the cargo should be strictly within the passenger cabin of the auto-rickshaw. It should not protrude or spill over to the driver cabin or outside the vehicle. As per specifications of a commercial auto-rickshaw (please see Appendix B), the overall dimensions permitted are: length - 2625 mm; width- 1300 mm, height - 1710 mm, and wheel base - 2000 mm. The permitted passenger cabin size¹³ is length - 1192 mm; width- 1150 mm, height - 1249 mm. The same volume measures can be used for the dual usage license.

It is important to ensure that the cargo does not fall off the auto-rickshaw and create a safety issue for other traffic. For this the passenger cabin can be covered by a door / partition, or the cargo needs to be tied by a harness to the auto structure.

Centre of gravity (CG)

With regards to the effect the cargo will have on the CG of the vehicle, we propose to ensure that the effect of the cargo on the CG of the vehicle should be the same as that due to passengers. Any cargo loaded into the auto-rickshaw should be so placed that its CG should at most be as high as that of the seated humans. This will ensure that the auto-rickshaw with cargo is as safe as an auto-rickshaw with persons sitting inside it.

Assuming weight of a human is 85 Kg and standing height is 170 cm, the sitting height of the human can be estimated to be 127.5 cm. With weight equally distributed, the CG of a sitting human approximates to 50 cm (Figure 1).

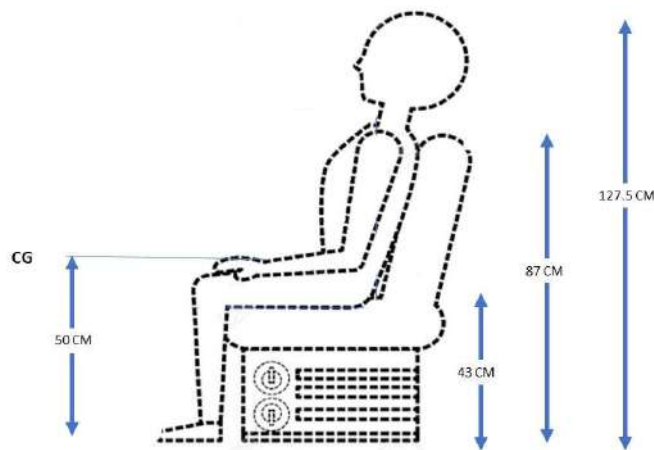

Figure 1: Human sitting in a Auto Rickshaw

¹³ Calculated using Figure 2 in Appendix B.

Therefore, whatever cargo is inserted into the autorickshaw, the cargo CG should not exceed 50 cm. Assuming that most cargo have fairly equally distributed weight, the cargo's height from the floor of the autorickshaw should not exceed 100 cm (i.e. double of the CG computed).

With regards to placement of cargo in the auto-rickshaw, a scheme is proposed in Figure 2. Zone A & C are for cargo placed directly on the floor. Zone A would be the most preferred zone and meant for heavy cargo. If cargo placed on the floor is high, its height should be within 100 cm. Zone B is for cargo placed on the seat. It should preferably be used only if Zone A is already full. It is also suggested that the cargo, irrespective of the zone it is kept in, should be securely tied to the frame/body of the auto-rickshaw, so that it does not fall off during the running of the auto-rickshaw (especially during manoeuvres like turning / braking, or on bumps).

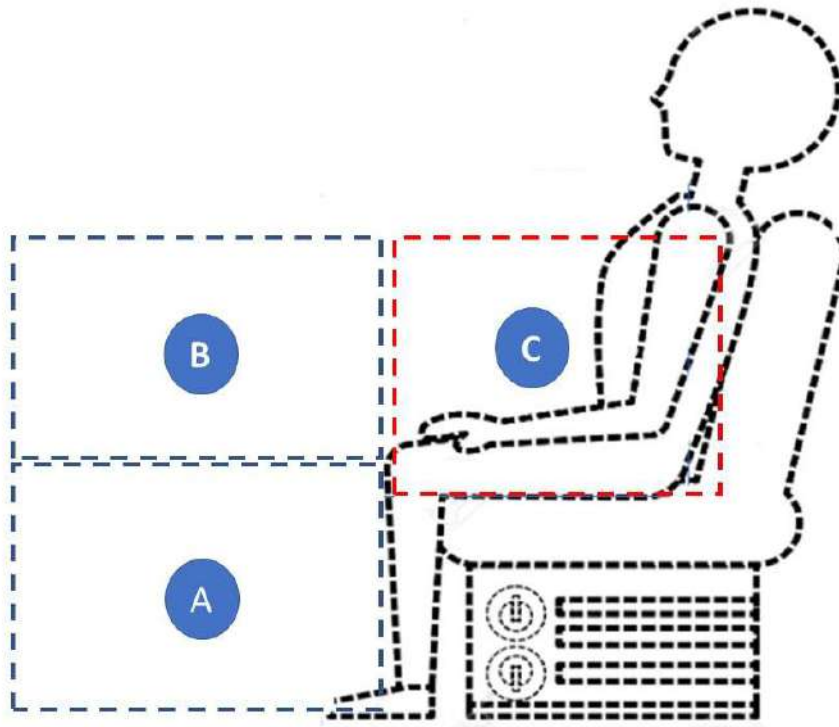

Figure 2: Placement of cargo in the auto-rickshaw.

Restriction on nature of goods

The nature of goods that are permitted to be carried should not cause a harm to the fellow travellers on the road and the driver. The prohibited items include narcotics or any other contraband, hazardous chemicals, arms and ammunitions, fireworks, other inflammable items and any other item which are specifically prohibited in the existing regulations.

Implementation:

Dual usage license would permit an auto-rickshaw to ferry both passengers and goods. These permits can be experimented for a shorter time in selected cities to assess whether revenues increase for the drivers and in-city logistics improves. During the experimentation period, the permits can list out the safety requirements as discussed above.

An initial experimentation period is recommended for the passenger auto-rickshaws to adopt to the new business opportunities, learn about the operations and sustain it. This period can also be used to assess the impact on the eco-system.

On successful operation of the experiment and assessment on the ecosystem, it will be open to the government to adopt the dual licensing at the time of new registration and will remain subject to such terms and conditions as it may be deemed appropriate by the authority including terms of periodic renewal. In this manner the dual licensed auto rickshaws will stand integrated to the in-city transportation system.

Conclusion

The paper examined the positive impact of dual usage license for auto-rickshaws in India. The proposed license shall increase the revenue potential of drivers, improve in-city logistics systems, has possibilities of increased trade and commerce, and can generate additional income to the state through taxes.

Following safety norms can be introduced to enable the dual usage:

1. Weight of the cargo needs to be less than 225 kg.
2. Volume of the cargo needs to be such that the cargo should not come out of the confines of the auto-rickshaw.
3. Height of the cargo needs to be lower than 100 cm from the floor of the three-wheeler auto-rickshaw. It should be placed either on the floor of the auto-rickshaw or on the seat, as per the zone plan.

A comparison of regulatory requirements shows that structural requirements for three-wheelers intended for passenger carrier (L5-M vehicles), and goods carrier (L5-N vehicles) have only one major distinction - the requirement for a separate load body or compartment for carrying goods. Consequently, any passenger three-wheeler can serve as goods carrier if the goods are transported duly following the proposed safety measures.

It is our belief that dual use policy for auto-rickshaws can benefit auto-rickshaw drivers, and have significant positive impact on in-city logistics systems. Safety is, of course, a paramount concern; and we believe that with the measures we have indicated, the safety of a cargo carrying auto-rickshaw shall be no inferior to that of a passenger carrying auto-rickshaw. However, we propose that the system should be tried initially in an experimental manner. This period, we believe, is needed for the stakeholders to adopt to the new business opportunities, learn about the operations and sustain it. This period shall help assess the impact of this change.

Central government under section 2B of the Motor Vehicles Act, 1988 has the power to exempt specified categories of vehicles from the applicability of the law to promote innovation, research, and development in the fields of vehicular engineering, mechanically propelled vehicles, and transportation in general. An experimental permission of dual usage may show new innovations in the transport segment.

Under Section 67(3) of the MV Act, state governments have the power to develop a scheme, or issue licenses for the promotion of development and efficiency in transportation, improving urban transport, and better utilisation of transportation assets. State governments can also exercise this power to permit this dual usage.



Appendix A: Persons killed in road accidents in terms of road user categories in 2020

Road-user category	Persons in killed in %
Pedestrian	17.8
Bicycles	3.2
Two-wheelers	43.5
Auto-Rickshaws	3.9
Cars, Taxis, Vans & LMVs	13.7
Trucks/Lorries	7.5
Buses	2.3
Other Motor Vehicles (including e-rickshaws)	2.5
Others (Animals drawn vehicle, cycle rickshas, hand carts, & other persons)	5.7
Total (1,31,14)	100

Source: MORTH. (2021). *Road Accidents in India 2020*. Ministry of Road Transport & Highways, Transport Research Wing, New Delhi.



Appendix B: Details of a commercial auto-rickshaw

Table 1: Specifications of a commercial auto-rickshaw (Bajaj)¹⁴

Engine	
Type	2 Stroke
Cooling Type	Forced Air Cooled
Displacement	145.45 cc
Max Power	7 bhp(5.15 kW) 5000 rpm
Max Torque	12.1 Nm @ 3500 rpm
Ignition Type	CDI
Transmission Type	4 forward and one reverse
Clutch Type	Wet multidisc type
Electrical System	
System	12V AC + DC
Head Light	35/35W
Horn	12 V AC
Chassis	
Chassis Type	Monocoque
Maximum Payload	333 kg
Suspension	
Front Suspension	Helical spring and hydraulic shock absorber with antitive link
Rear Suspension	Independent suspension with spring and hydraulic shock absorber
Tyres	
Front Tyre Size	4.00-8, 4PR
Rear Tyre Size	4.00-8, 4PR 2 Nos.
Brakes	

¹⁴ <https://www.indiamart.com/rohanautoparts/three-wheelers.html>

Front Brakes	Drum Hydraulic
Rear Brakes	Drum Hydraulic
Fuel Tank	
Fuel Tank Capacity	8 liters
Dimensions	
Overall length	2625 mm
Overall width	1300 mm
Overall height	1710 mm
Wheel Base	2000 mm
Ground Clearance	180 mm
Minimum Turning Radius	2.88 m
GVW - The gross weight of a vehicle	277 kg

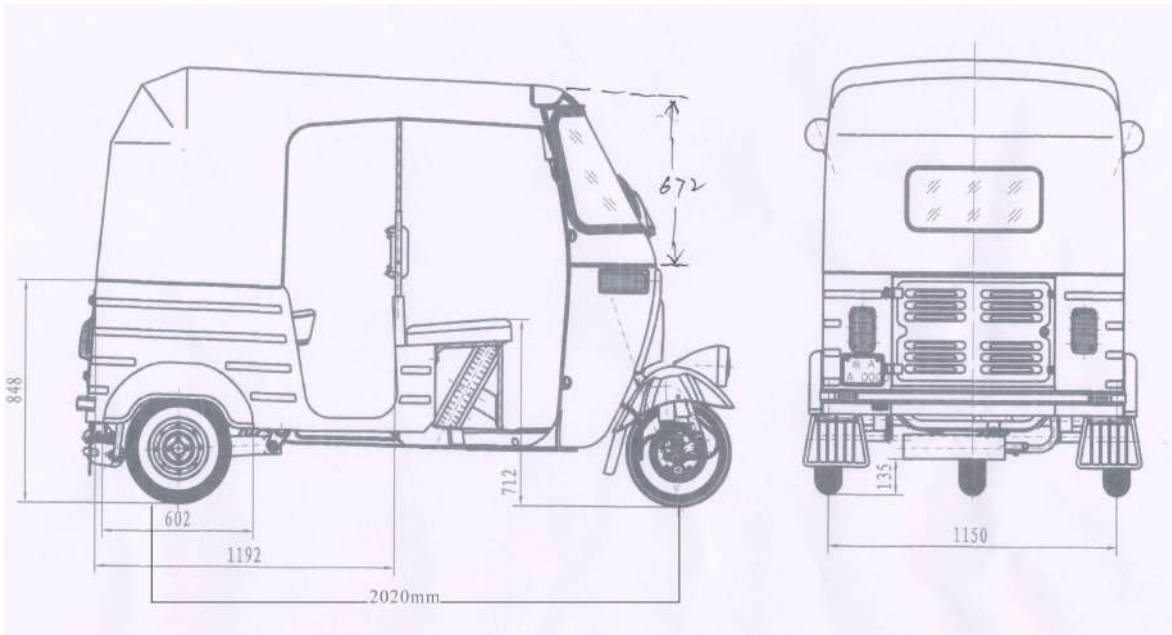

Figure 1: Line diagram of a commercial auto-rickshaw¹⁵

¹⁵ <http://www.auto-rickshaw.com/cl1.html>

Dr. Jaijit Bhattacharya, President
Centre for Digital Economy Policy Research (C-DEP)

Email: president@c-dep.org

Website: <http://www.c-dep.org/>